

Design of Process Equipment

Column devices

Lecture

doc. Ing. Martin Juriga, PhD.
Bratislava, February 2024

Column devices

Column devices / Distillation
Rectification, adsorption,
absorption, quenching,
extraction / are one of the
most frequently used types of
separation devices in industry.

They are devices that serve to
separate one or more
components from a gas or
liquid mixture.

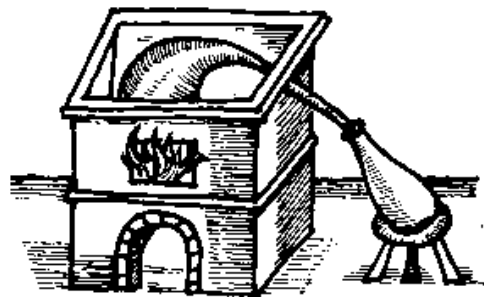

Illustration of Distillery Workers, c. 1580-1605. In the foreground, two men are consulting with a book. Others carry out the distillation process. The Invention of Distillation is the seventh record in a print series called *Nova Reperta* (New Inventions of Modern Times).

Process design

It is complex.
 Knowledge of all

HEAT TRANSFER
 MASS TRANSFER

Today, preferably on
 a PC with simulation
 programs such as
 ASPEN.

5th year of
 Honeywell UNISIM

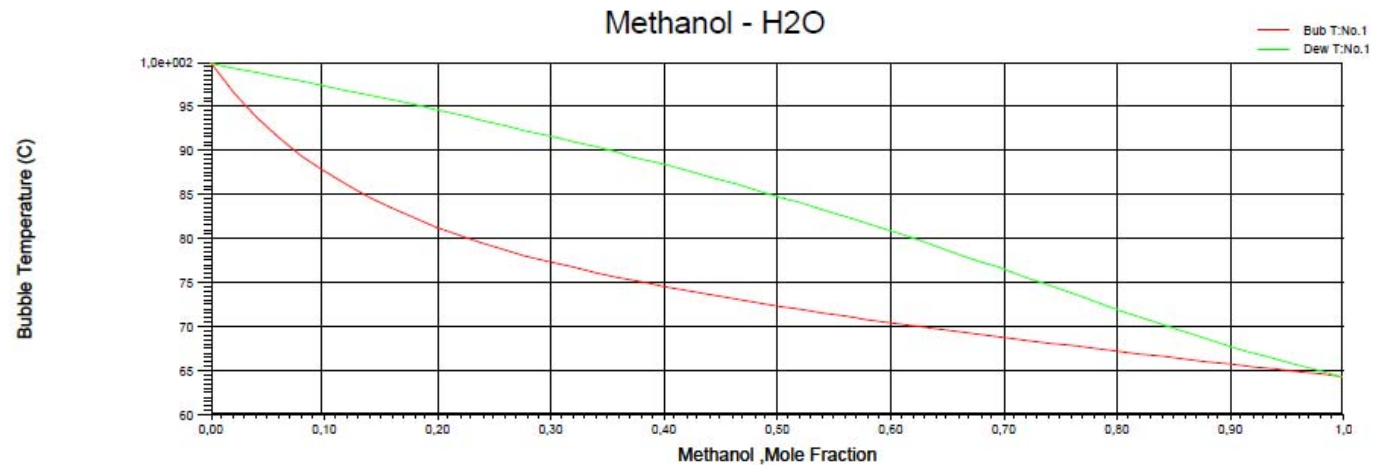
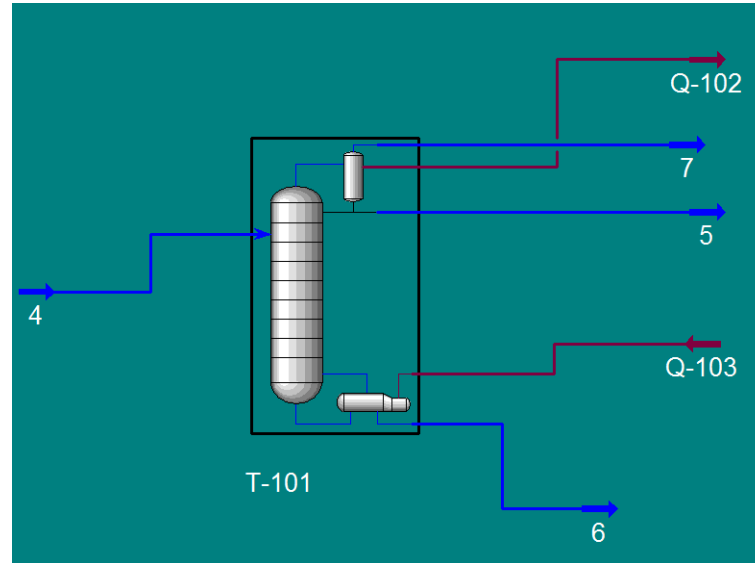

Column devices

General information

Division according design

- Trayed : /Bubble cup tray, Sieve, Valve, etc ../
• Packed Bed

Column

It is a mass exchanger, usually cylindrical in shape with an internal structure that ensures the transfer of mass during the countercurrent movement of the phases.

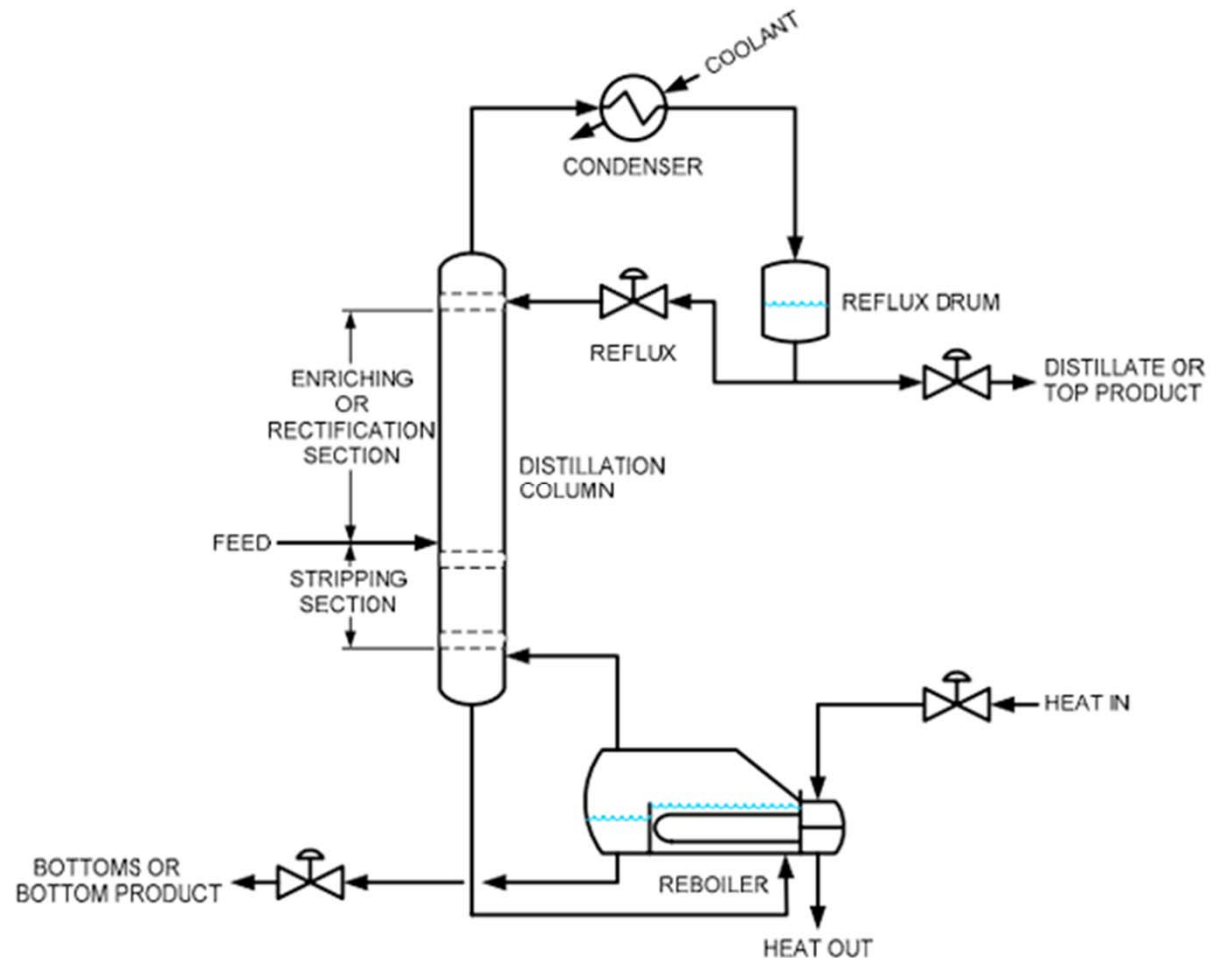

Trayed column

Bubble cap trays

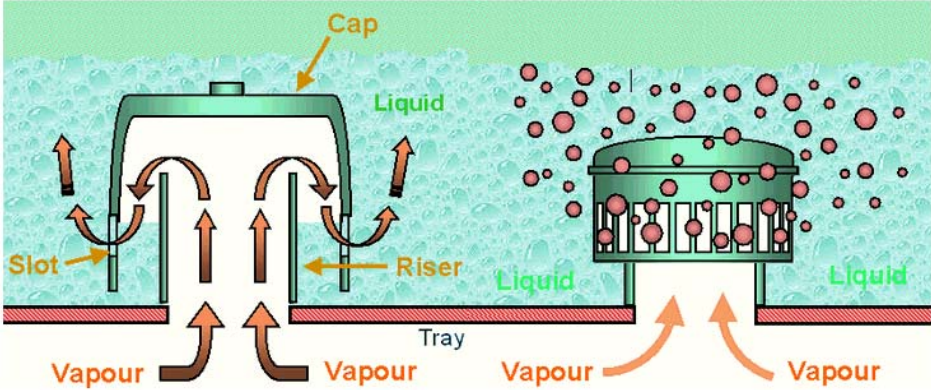
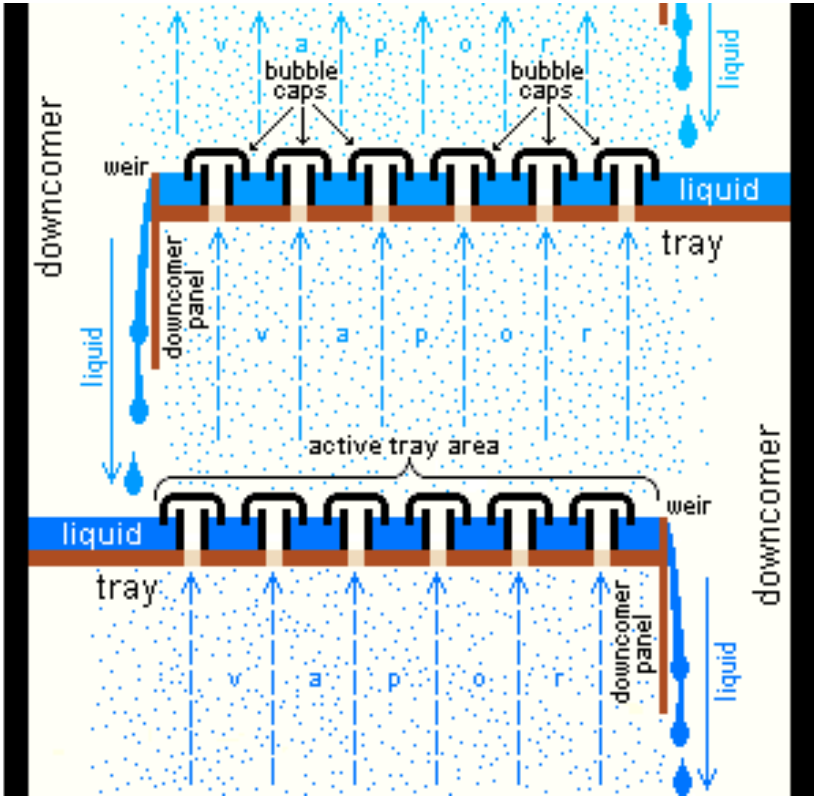

Trayed column

Sieve Trays

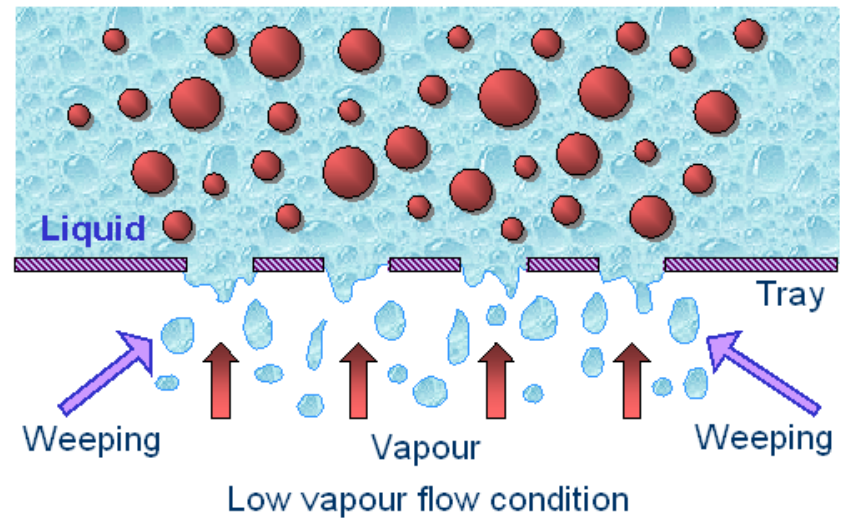
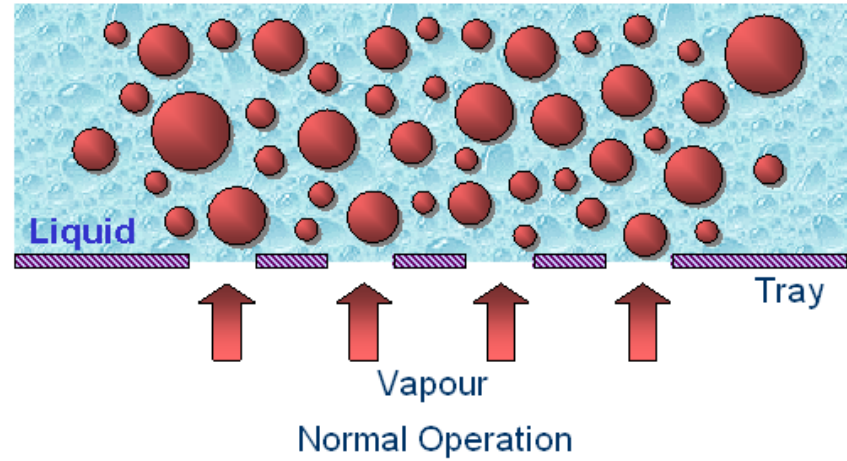
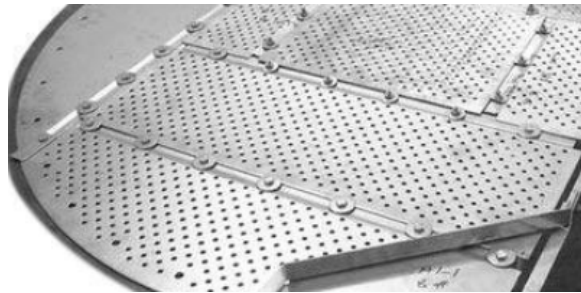
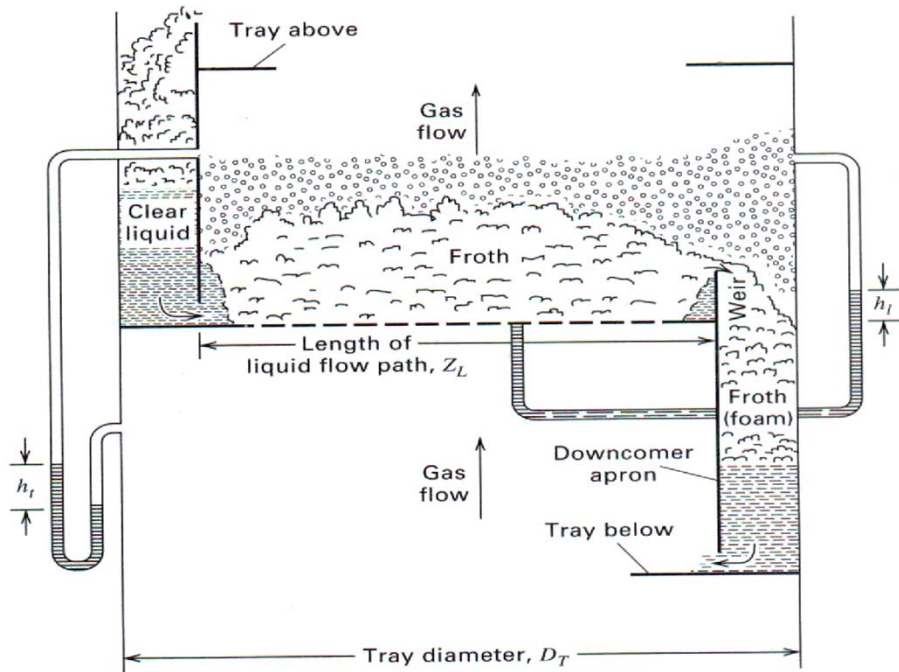

Trayed column

Valve trays

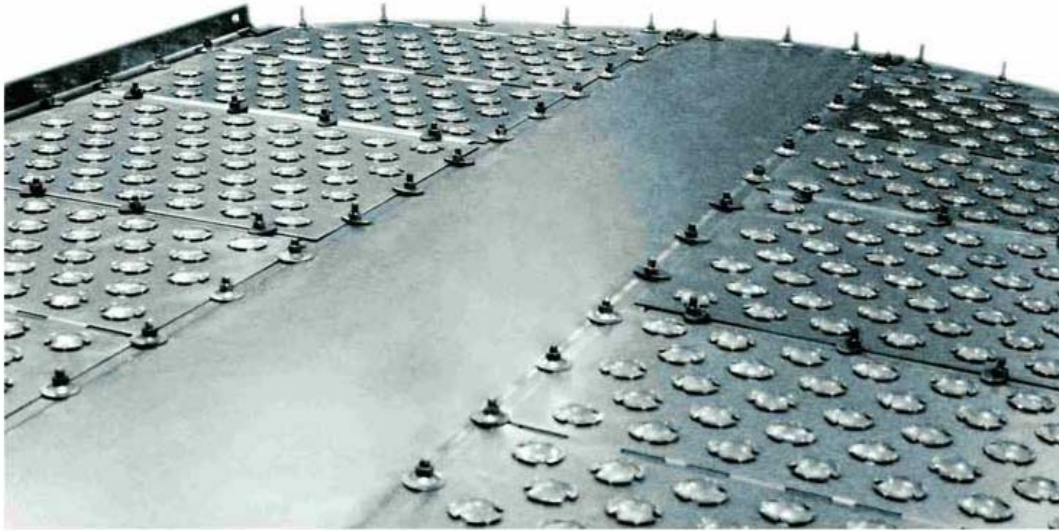
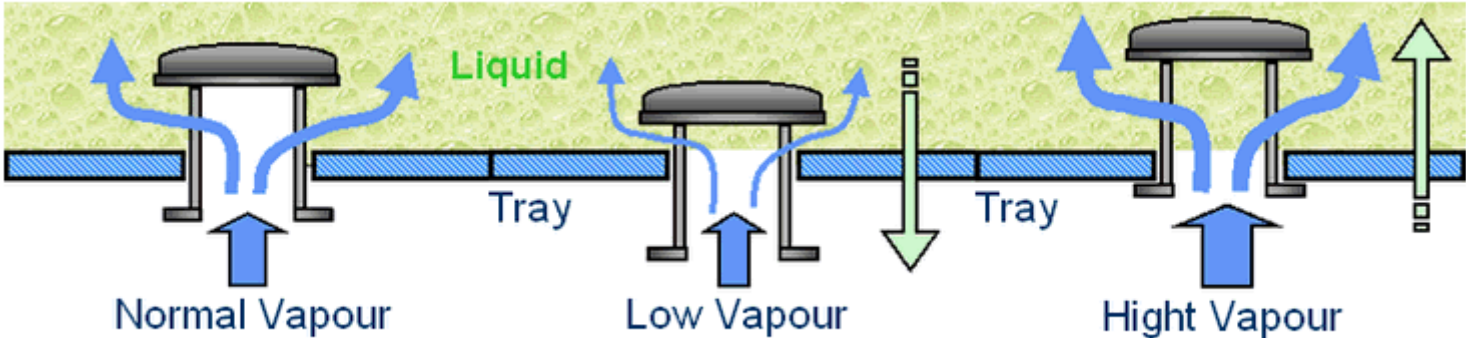

Packed bed column

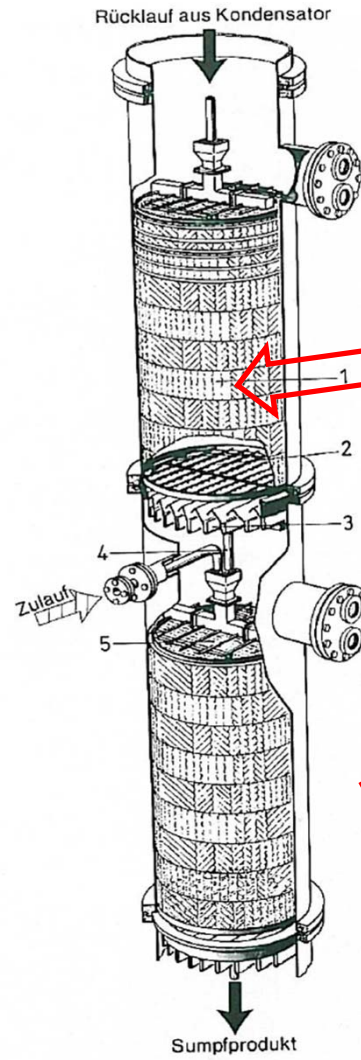
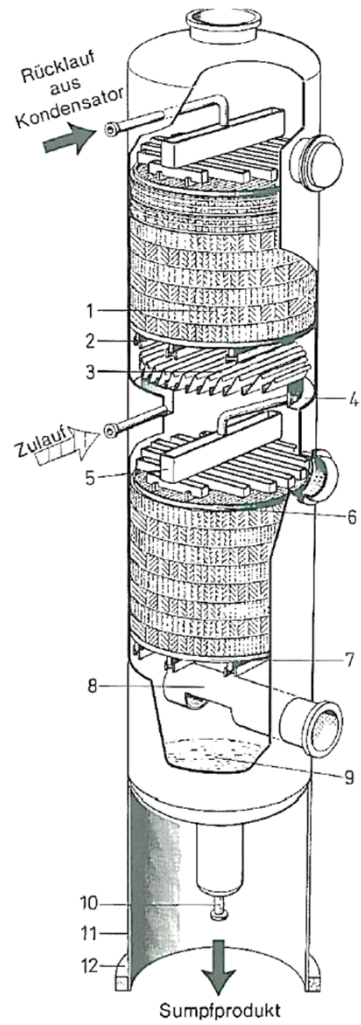

Packed bed column



Packed bed column

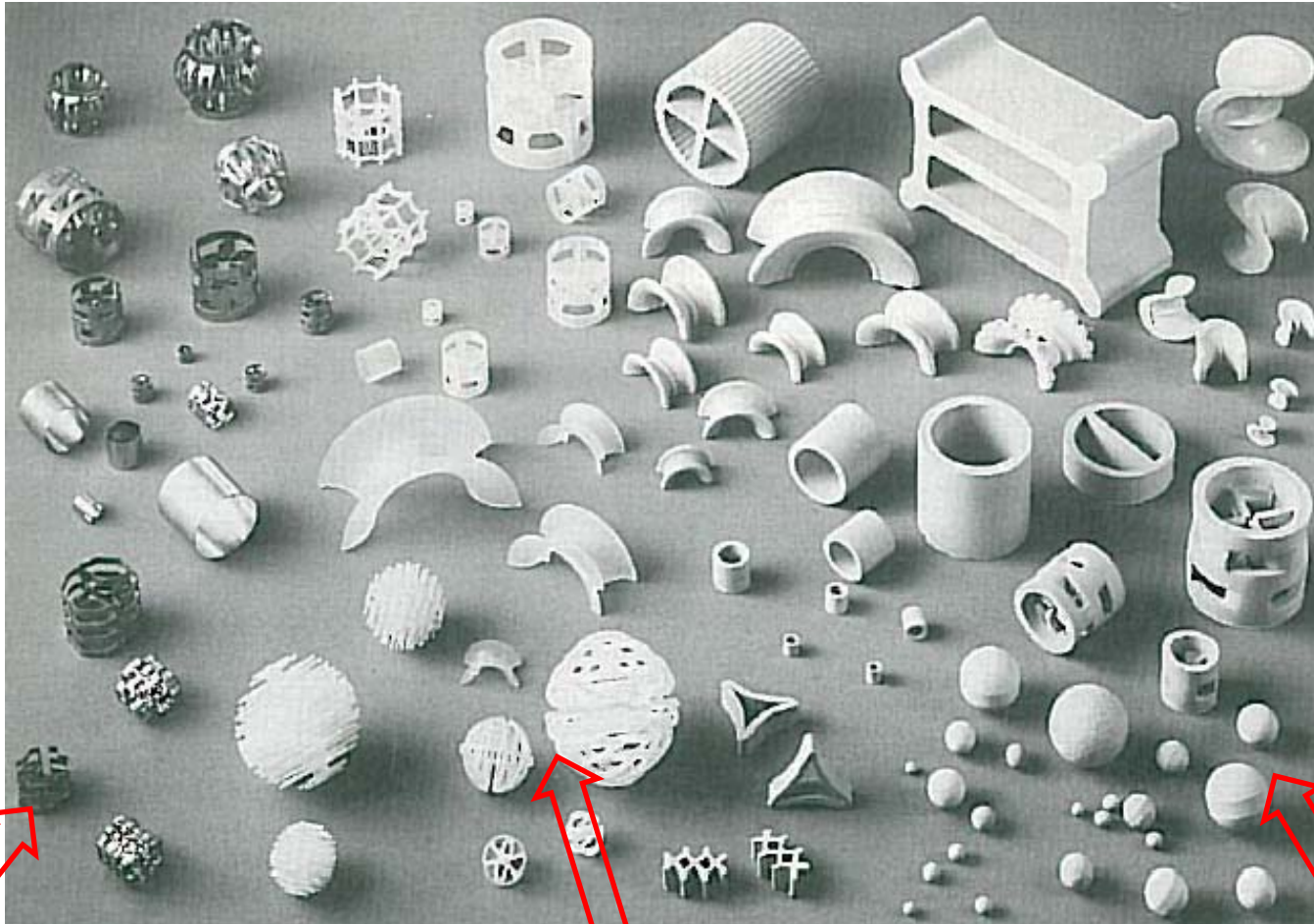

Oceľ

Plast

Keramika

Packed bed column

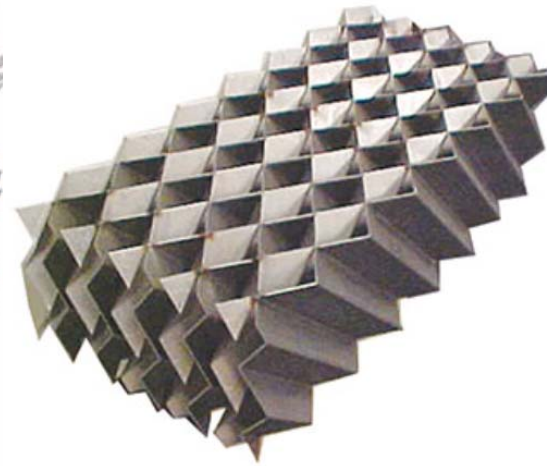
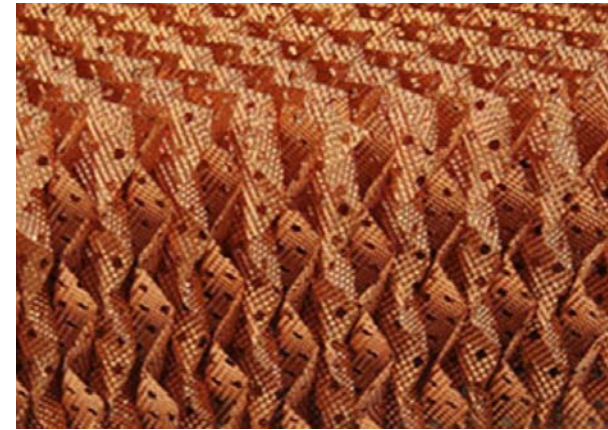
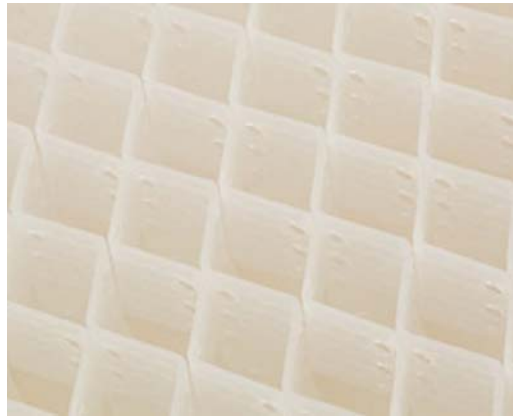
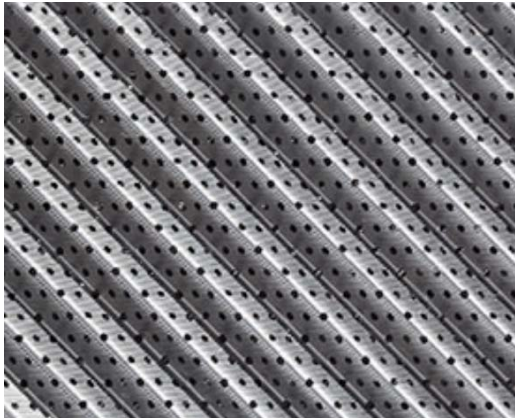

Packed bed column - Flange

For small dimensions /
approx. 900 mm/, the
column is manufactured
as a flanged column for
assembly

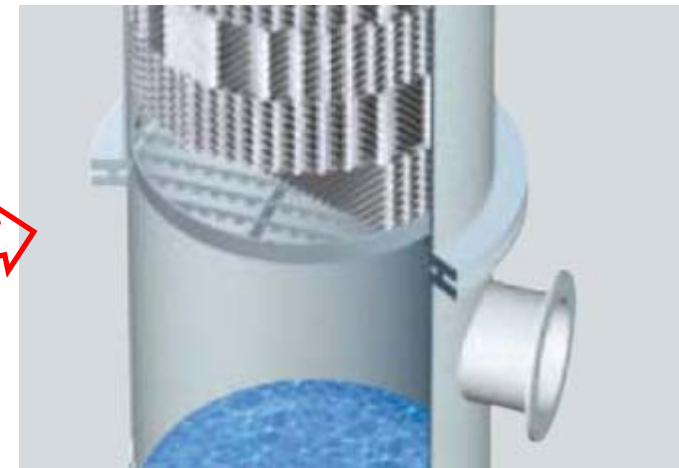
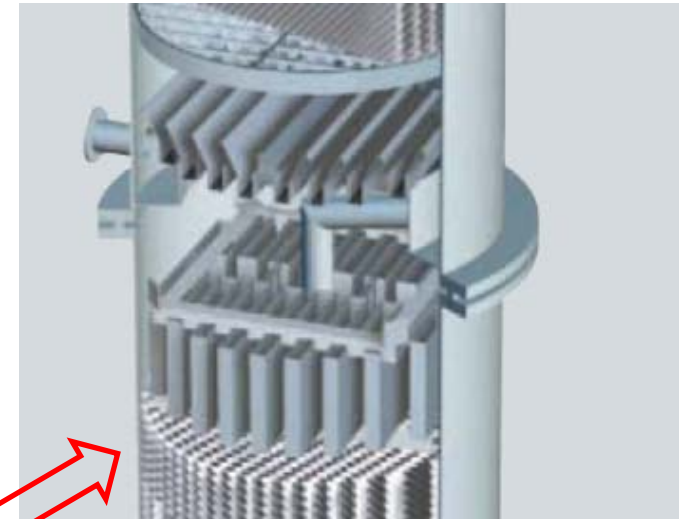
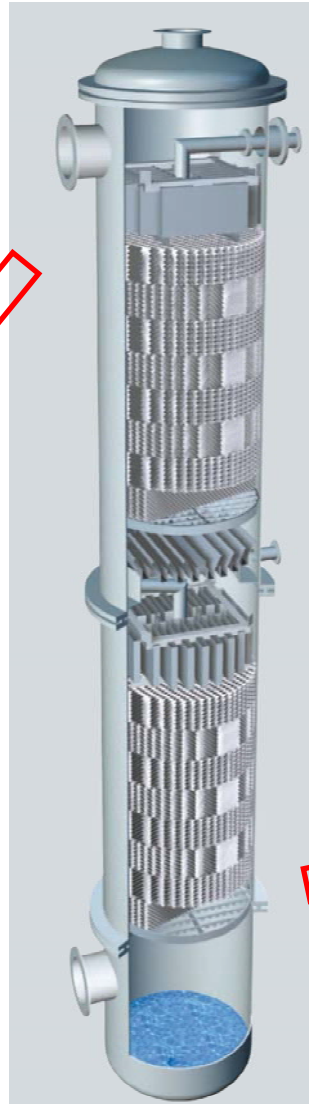
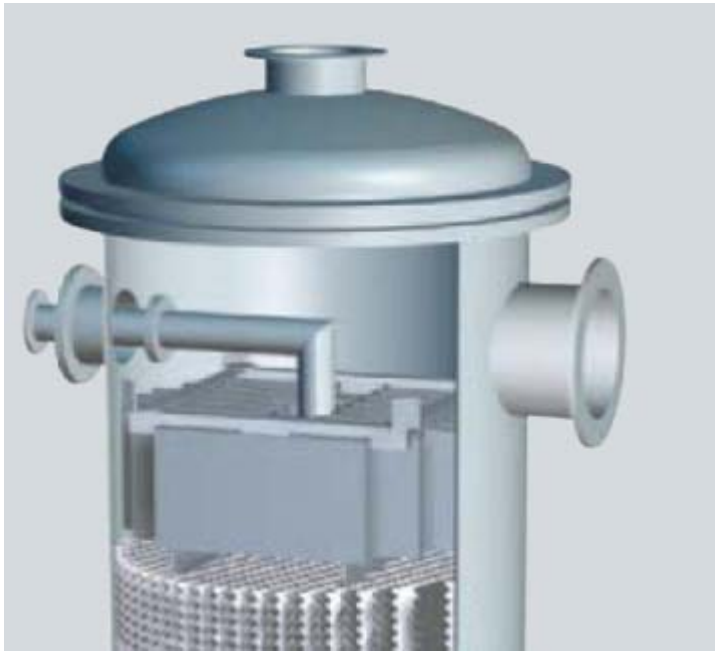

Packed bed column – no flange

For larger diameters / over 900 mm/, the column is manufactured as fully welded.

For the assembly of individual sections and parts, it is necessary to equip the device with manholes /MANHOLE/ min. DN600

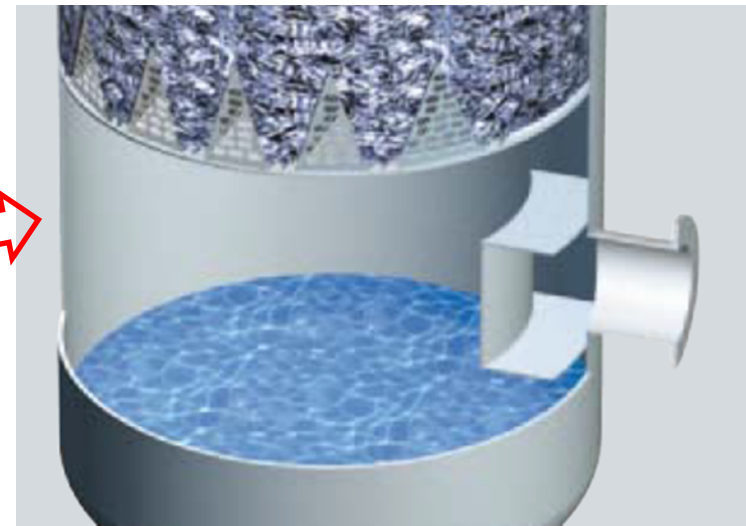
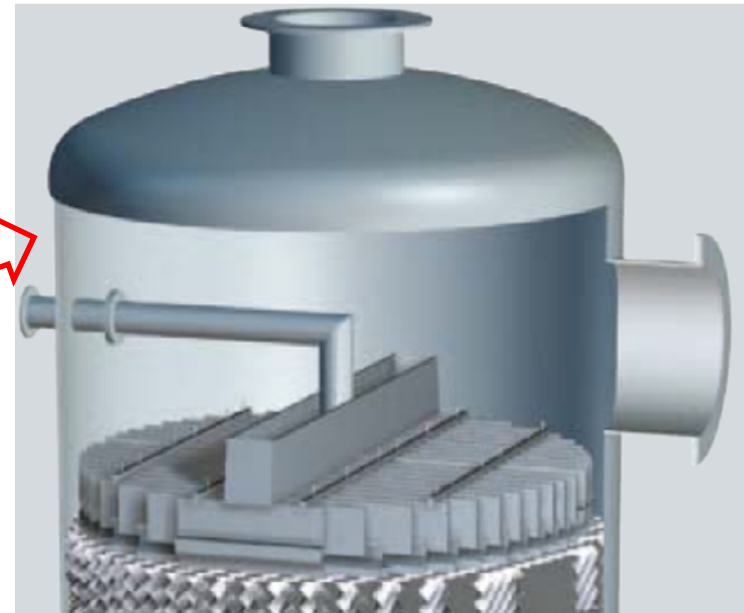
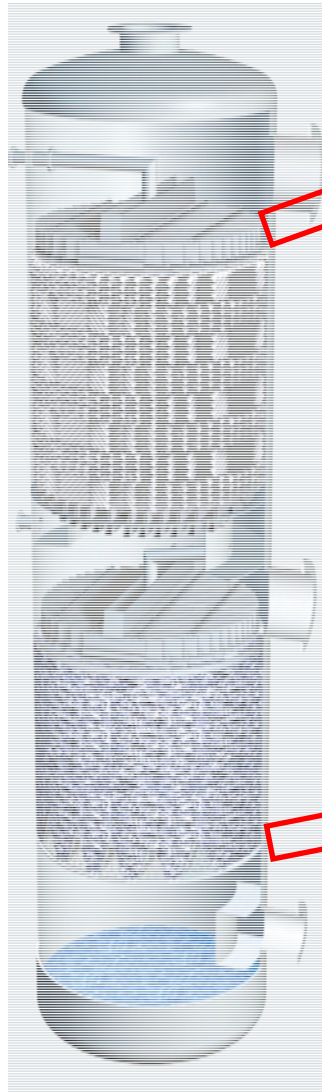

Demister /Mist eliminator/

It is part of a column
Alternatively, it is a separate device,
included in the technology

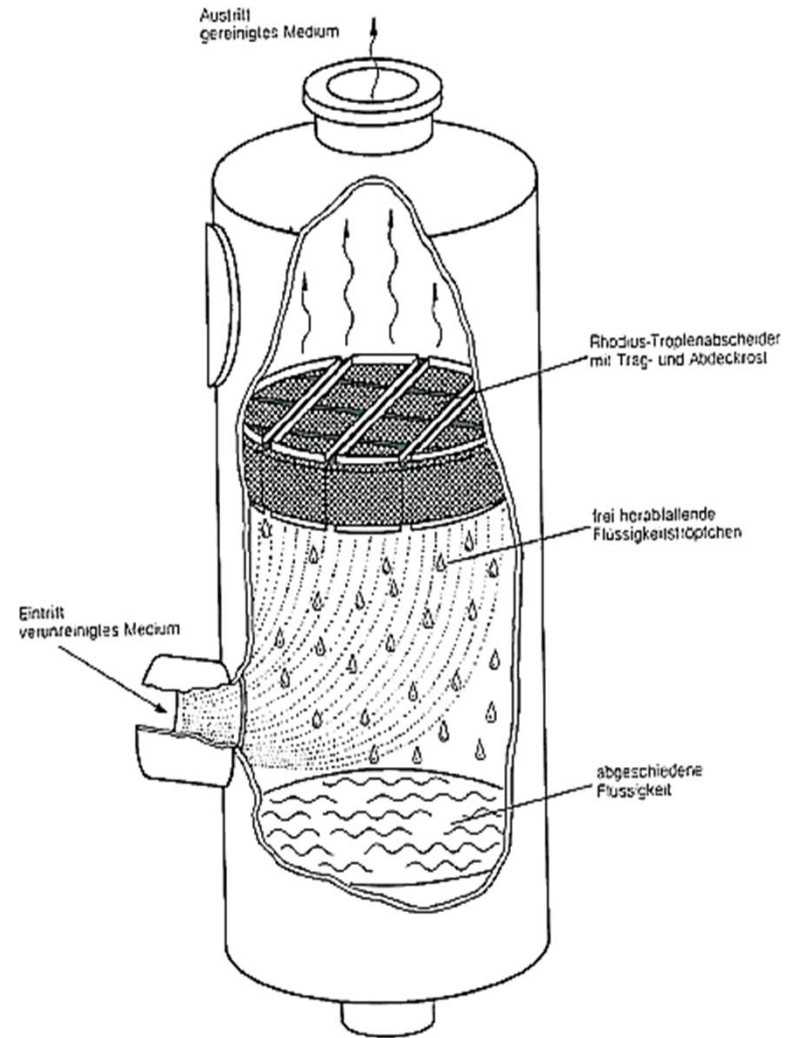
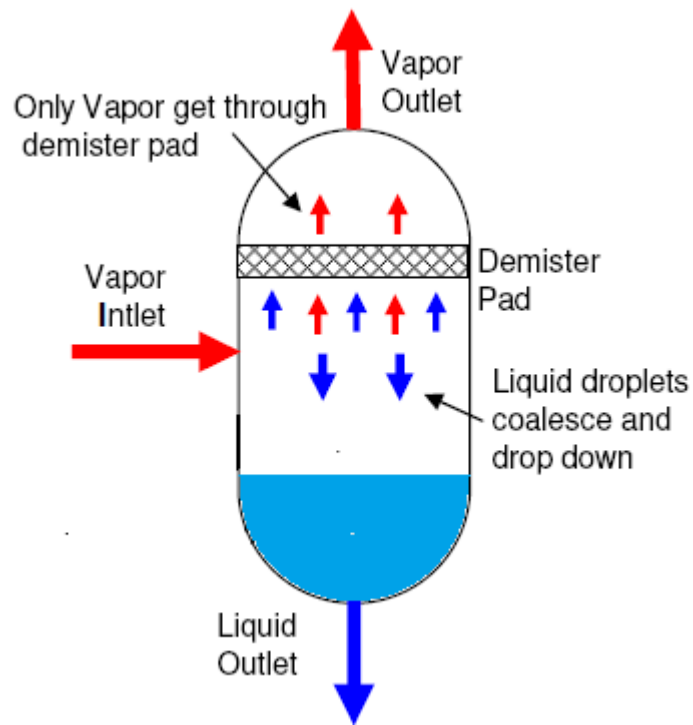

Demister /Mist eliminator/

Droplet formation

Benefits: Reduction of valuable losses
Chemicals

Capacity increase

Increase in product purity

Reduction of contamination

Equipment protection

Reduction of environmental pollution

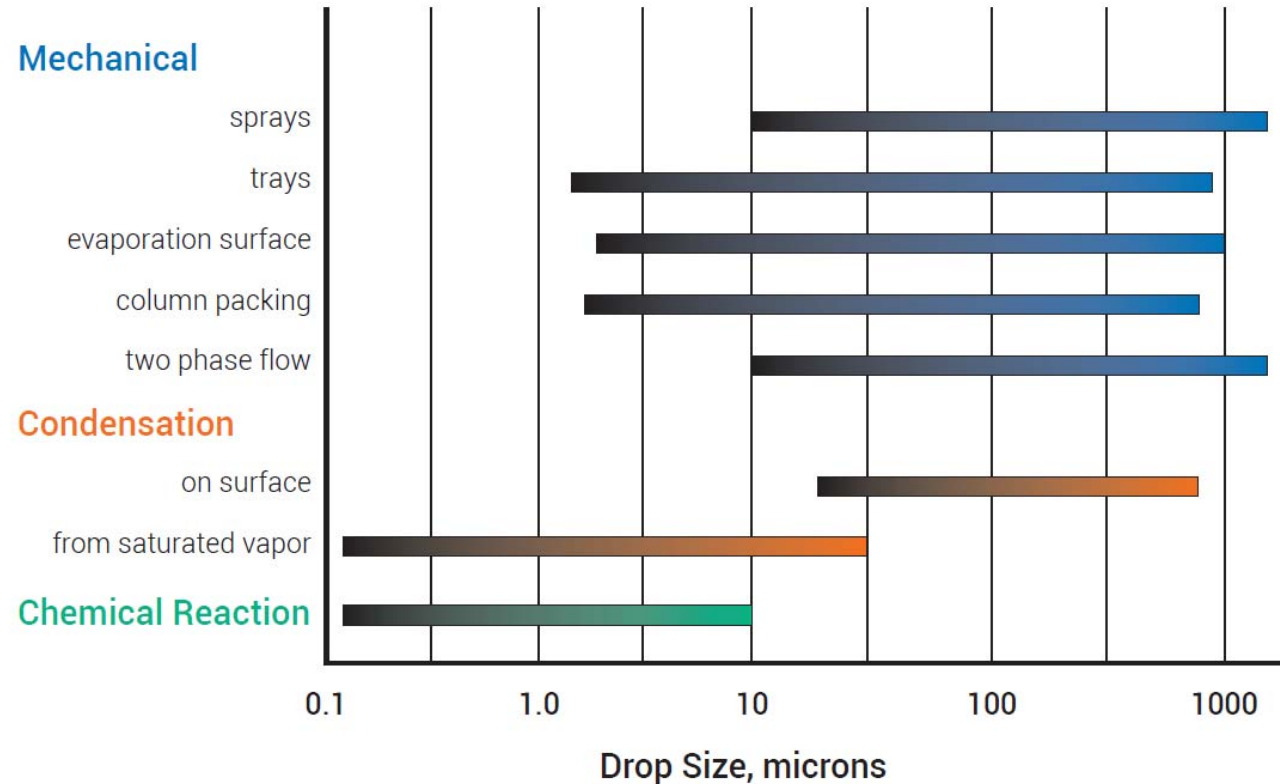

Demister /Mist eliminator/

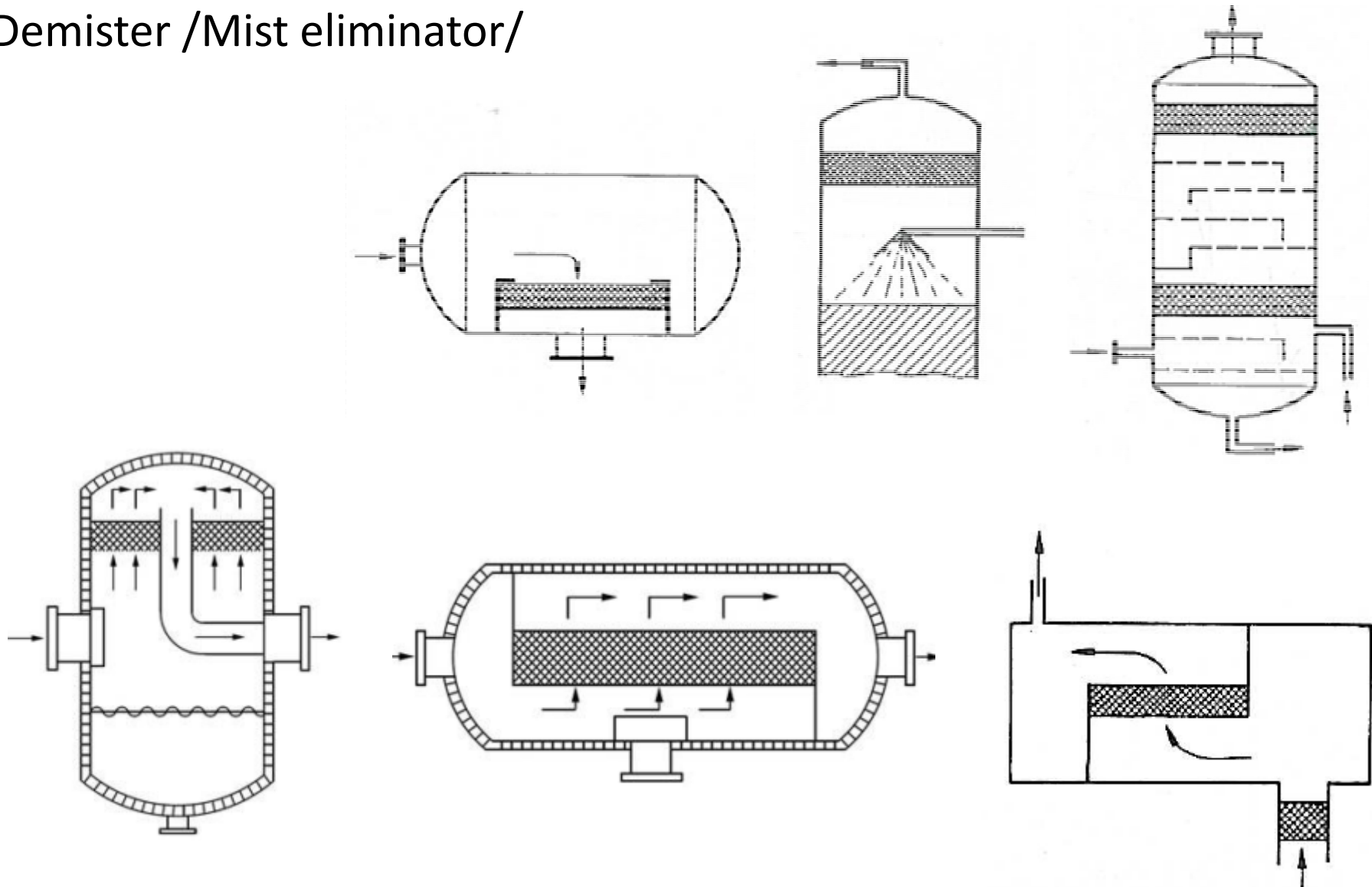

Demister /Mist eliminator/

Fixing
and
installation

Einbau und Befestigung von unten

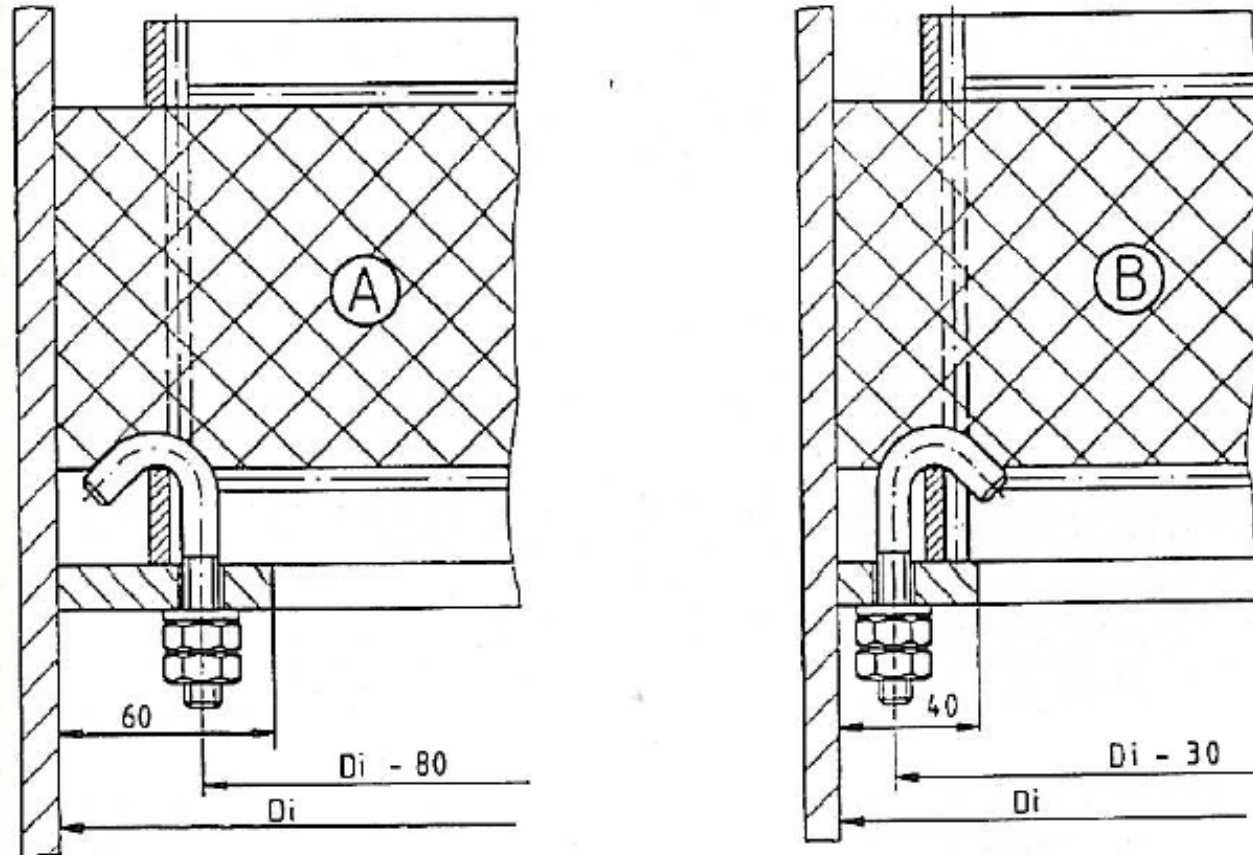

Demister /Mist eliminator/

Fixing
and
installation

Einbau und Befestigung von oben

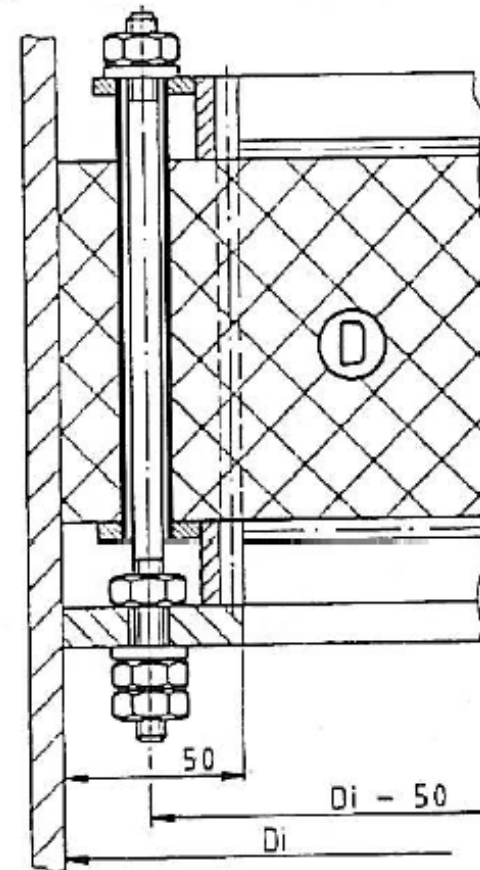
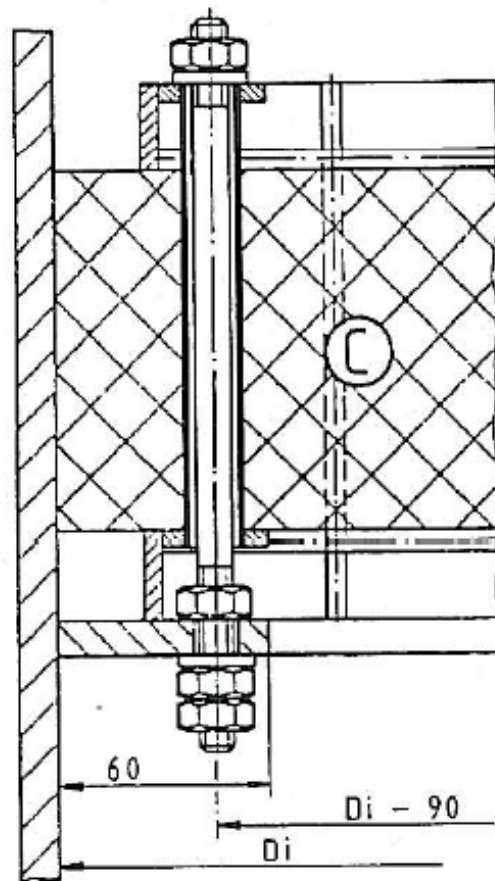

Demister /Mist eliminator/

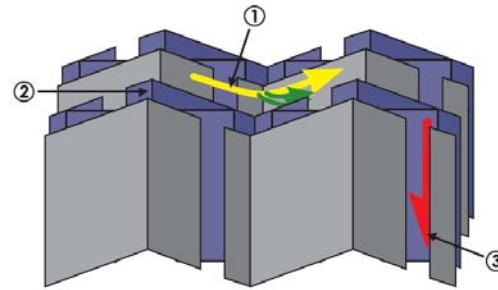

Horizontal gas flow.

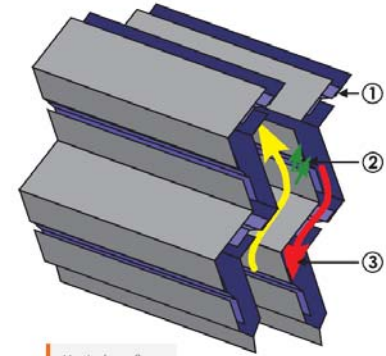

Vertical gas flow.

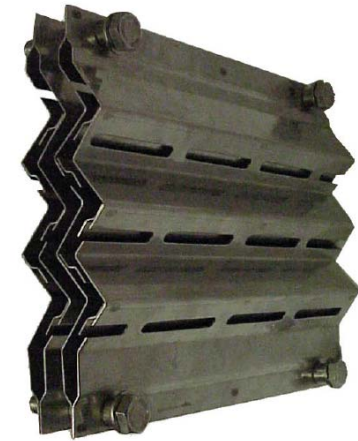

Liquid distributor

It ensures the best possible distribution and re-distribution of the inlet liquids

Gravity

Spray Nozzle

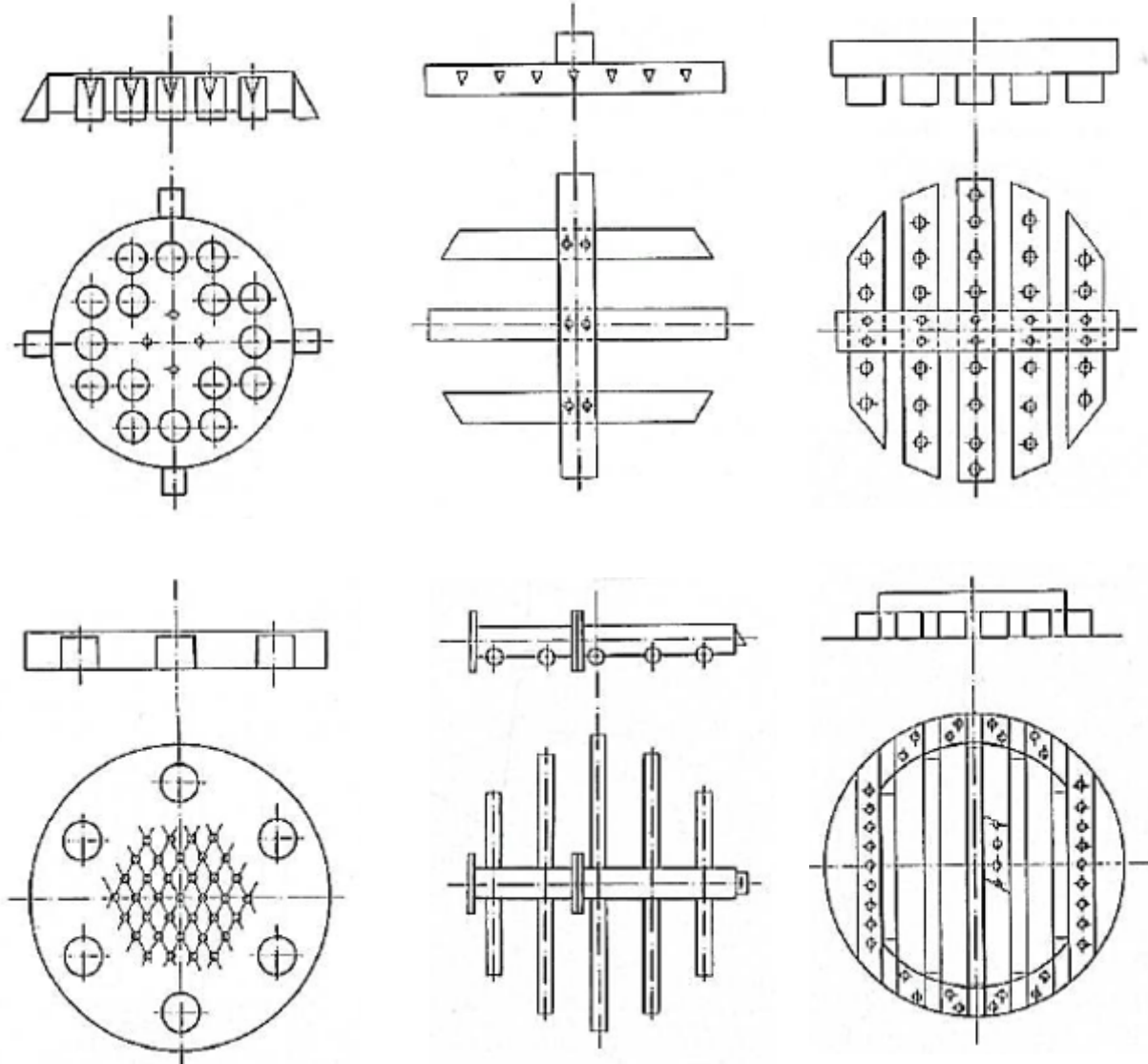

Liquid distributor

It ensures the best possible distribution and re-distribution of the inlet liquids

Gravity
Spray Nozzle

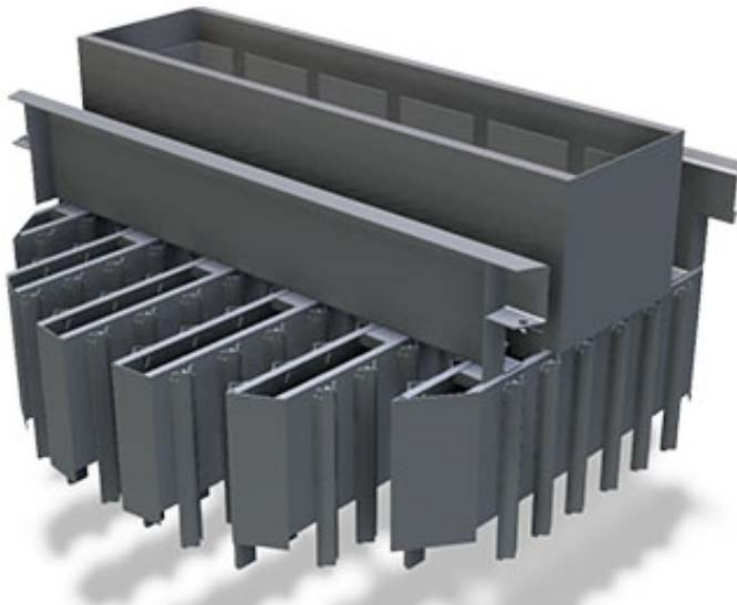

Support plate

For Packed bed column
column devices

Different types

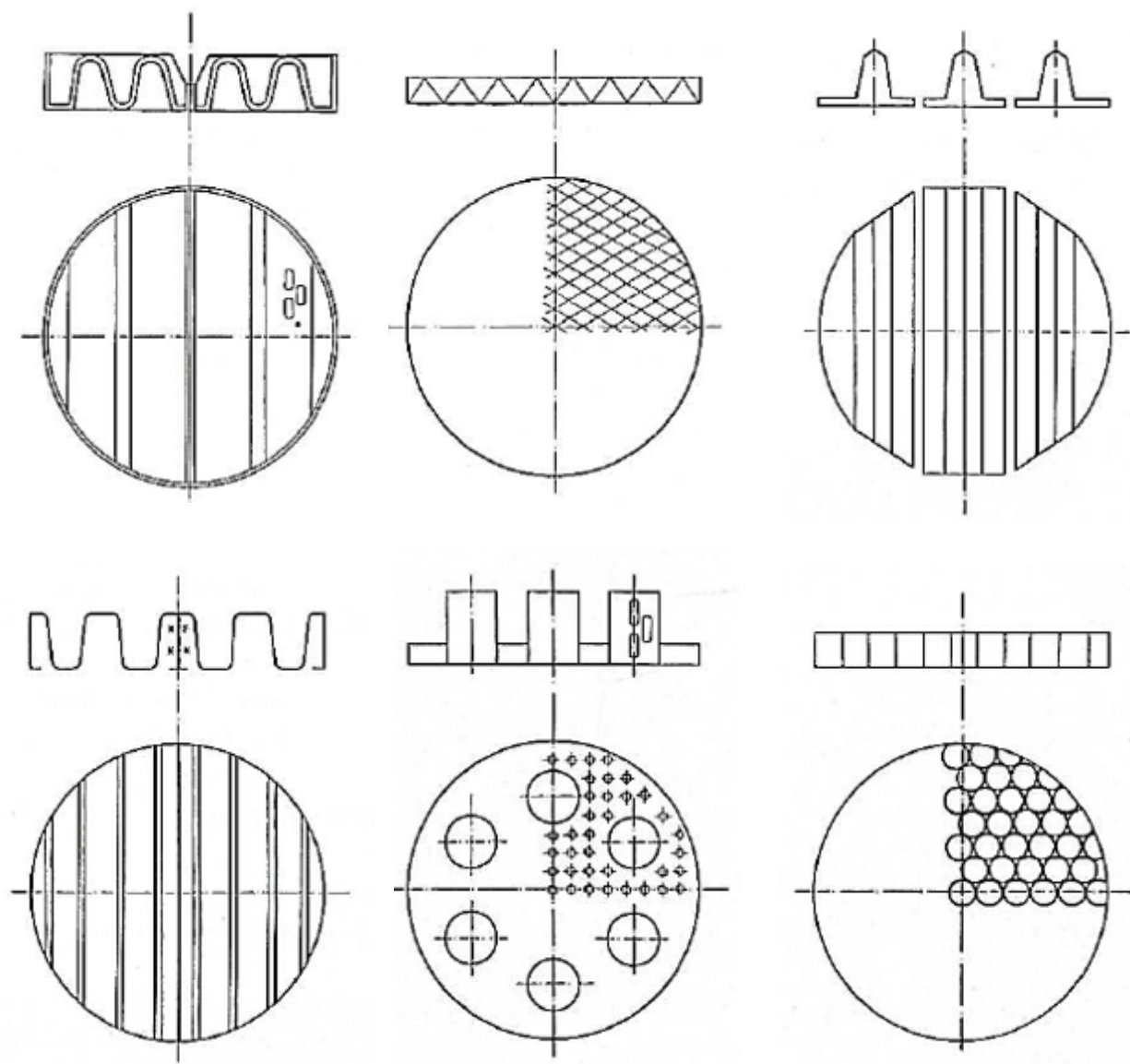

Support plate

Fixing method

Welded

Demountable

Maximum load capacity

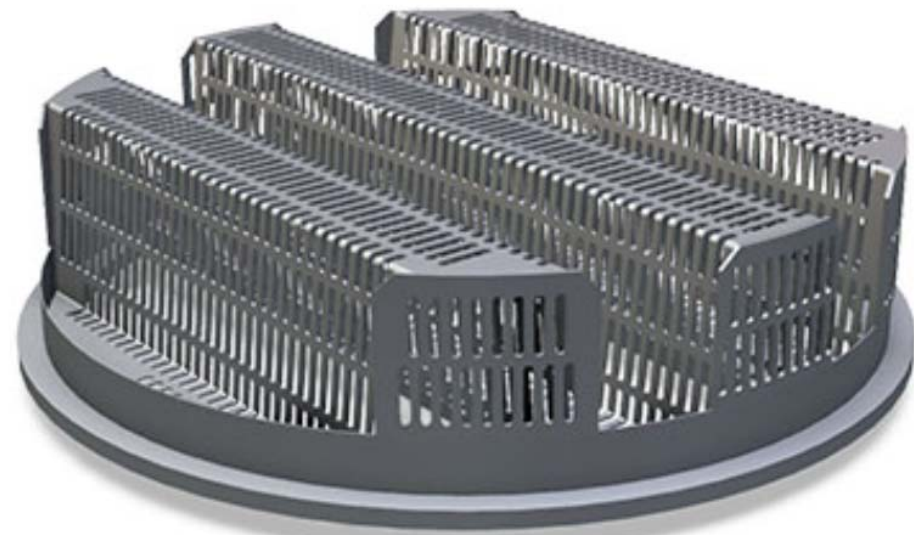
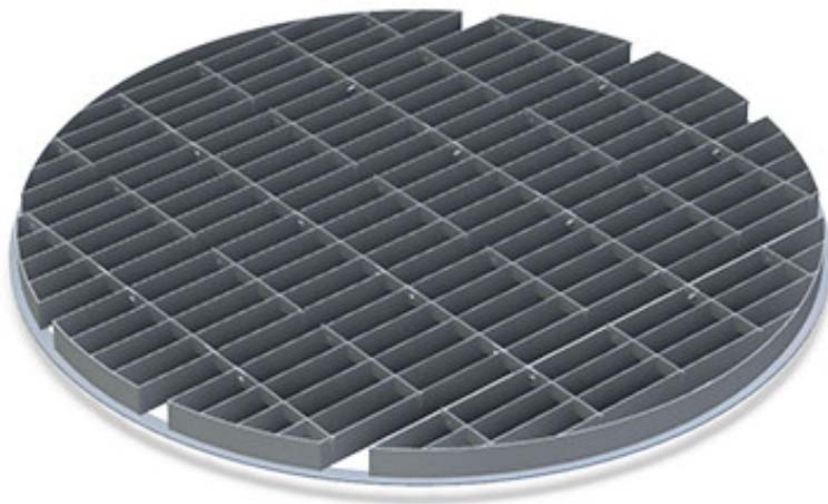
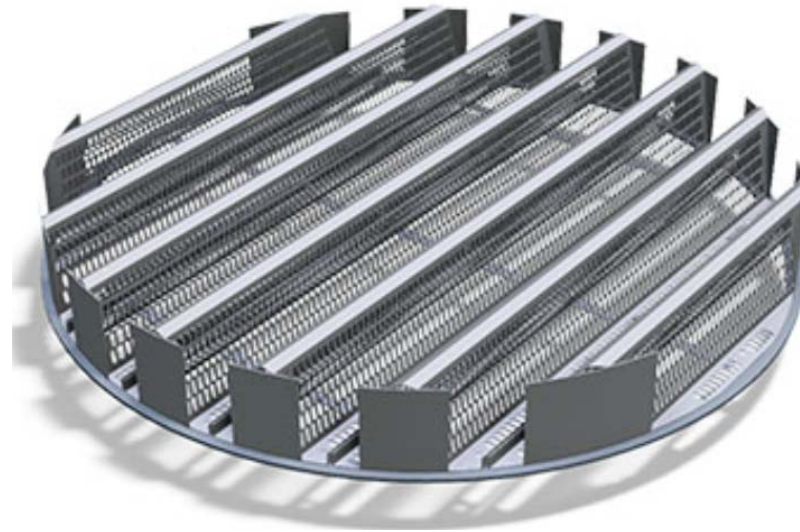

Support plate

Fixing method

Welded

Demountable

Maximum load capacity

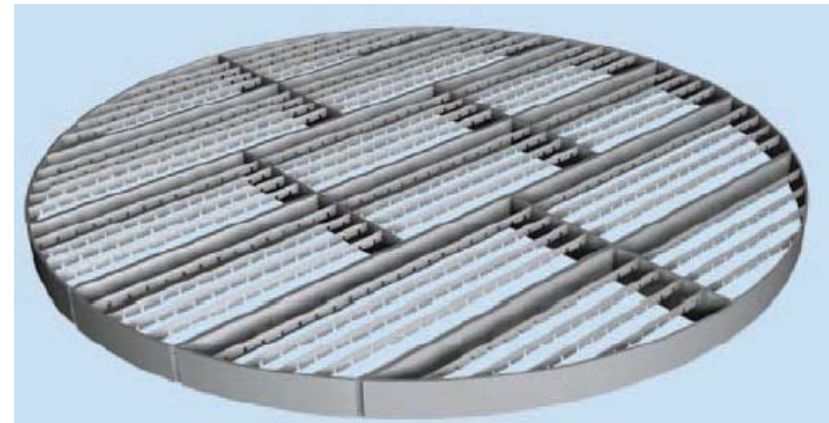

Inlet pipeline

Gas

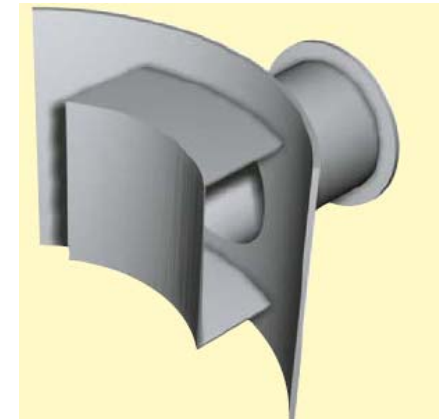
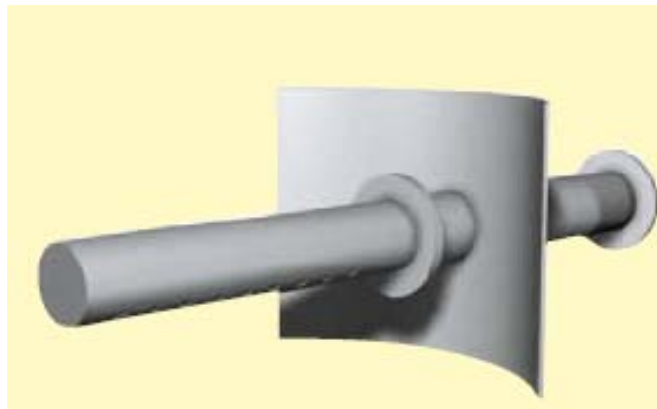
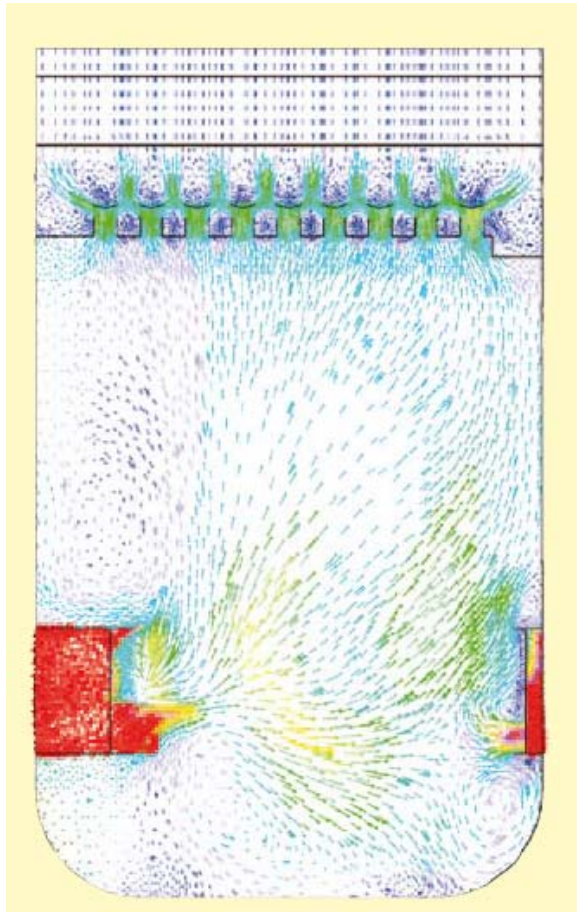

Inlet pipe

Liquid

